

D-LINE HD32-A

TWO-WAY SYSTEM



DESCRIPTION

The HD 32-A it's a unique product in his category. The titanium dome, 3.0" voice coil compression driver offers a unique vocal clarity and sound projection.

At the core of HD 32-A design is the new ND 840 compression driver. The ND 840 large format compression driver delivers one of the key advantages of the HD32-A, the 3.0" voice coil allows a crossover point of 800Hz and therefore almost all of the vocal range can be produced by this driver. This allows better coverage and dispersion control, and superior efficiency. All Compression drivers and Transducers are precision built taking advantage of RCF's superior moulding, assembly technologies and a wealth of professional knowledge and experience dedicated to achieving extremely high standards. The HD32-A offers an extremely linear response and a precise, deep low frequency control. The 12" woofer guarantee a superior sound projection indoor and outdoor. It is the ideal speaker for main front of house in small PA systems, for high power monitoring and it is the best solution where higher power is required for various applications in larger venues. The concept of this unique speaker derives from the touring industry, bringing in a compact cabinet all the experience of RCF professional sound. The new 12" woofer is the result of the latest refinement in year of RCF experience in compact 2 way speakers. Features a 3 " voice coil, very high efficiency and controlled bass reproduction.

RCF HD32-A is equipped with a new generation of 700 Watt Digital Amplifier. RCF Class-D power amplifiers technology packs huge performance operating with high efficiency into a lightweight solution. D Line amplifiers deliver ultra fast attack, realistic transient response and impressive audio performance. The amplifier features a solid mechanical aluminium structure which not only stabilize the amplifier during transportation but also assist in the heat dissipation.

All the D-LINE amplifiers presents SMPS power supply section in order to produce maximum output and minimum transportation weight. The integrated DSP manages crossover, equalisation, soft limiter, compressor and dynamic bass boost. Switchable EQ Mode make it easier to select among two different equalisation presets: Extended response switch, which slightly emphasizes the bass response for playback music and low volume applications and Linear response switch, for using the speaker to amplify a live mix.

A useful Mic/Line switch to adjust the input sensitivity is provided. When used just for speech, the Mic setting allows to use a microphone directly with the speaker. Set the selector to Line when using the speaker for live music or playback.

An easy to reach volume knob on the back allows to set the overall volume of the speaker according to its application.

3 status LEDs – Power / Signal / Status are provided for monitoring the system.

D LINE cabinets are moulded on a special polypropylene composite material designed to dampen down vibrations even at maximum volume settings. From moulding to the final texture, D LINE offers the maximum reliability and strength for the intensive use on the road. The reflex porting has been resized to offer a better efficiency. The HD32-A features 3 ergonomically designed forged handles with rubber handgrip, 2 on the sides and one at the top. At the bottom a rugged steel pole mount has been installed in all models. The new cabinet shape will allow every D-LINE model to be used in the standard configuration as well as in stage monitor model. Two M10 and 3 M6 threaded inserts are provided for optional mounting hardware in Installed Sound Applications.

MAIN APPLICATIONS

- Live Sound
- DJs
- Portable PA
- Stage Monitoring
- Clubs
- Voice reinforcement

MAIN FEATURES

- 1400 Watt
- Digital Bi-amplification
- DSP Sound Processing
- RCF Precision 3.0" voice coil compression driver, titanium dome
- RCF Precision 12" woofer
- 131 dB MAX SPL
- Powercon Input/Output



D-LINE HD32-A

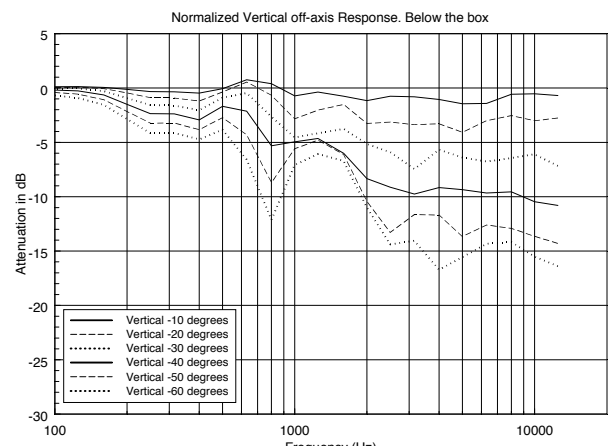
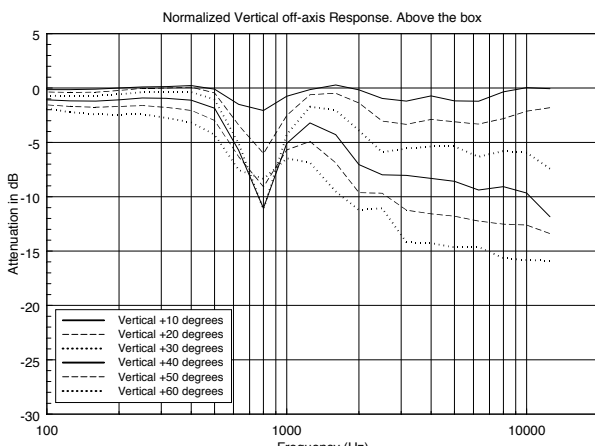
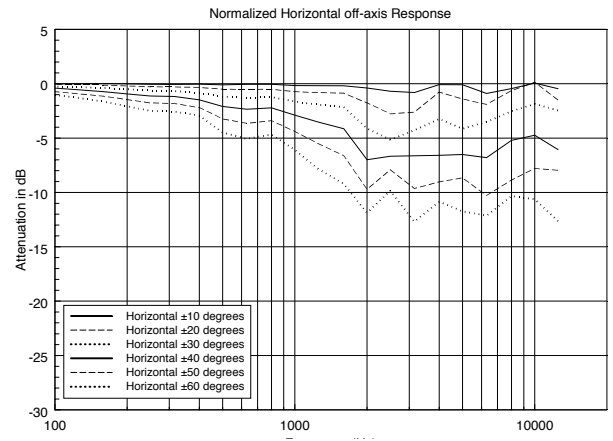
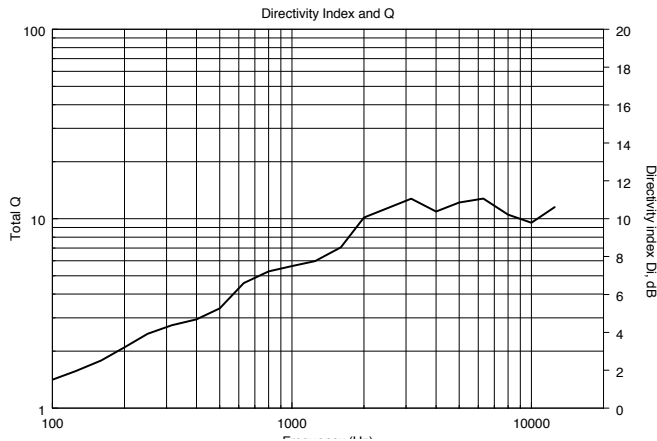
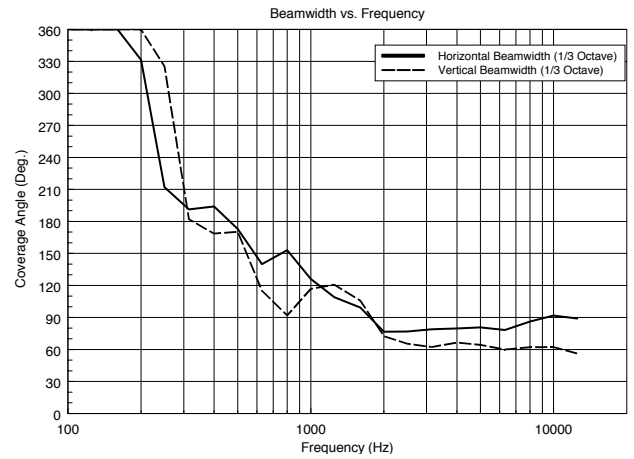
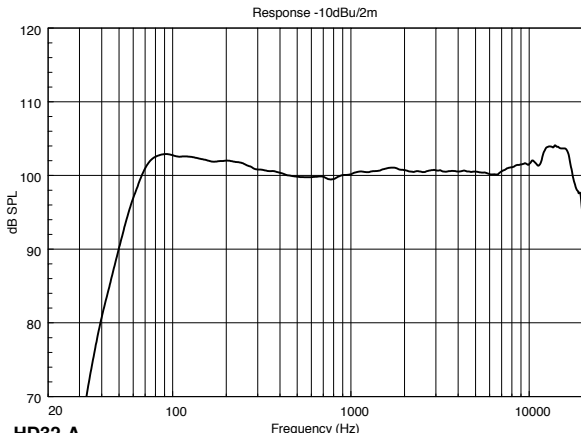

D-LINE HD32-A

HORIZONTAL 1/3 POLAR PLOT

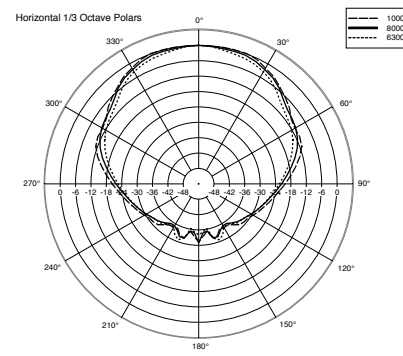
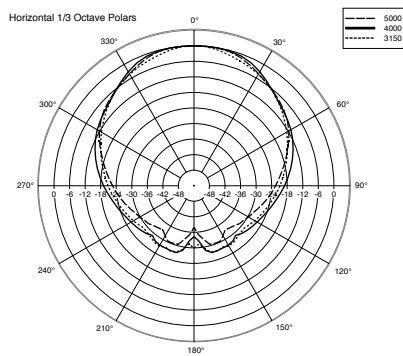
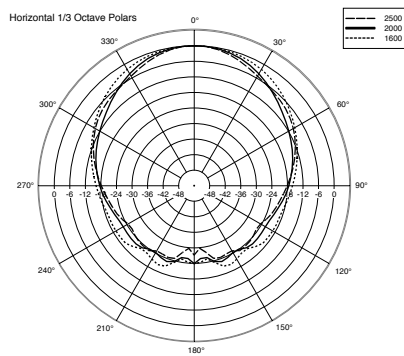
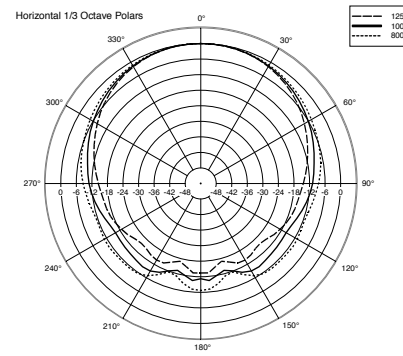
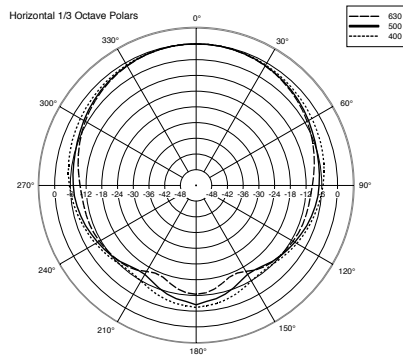
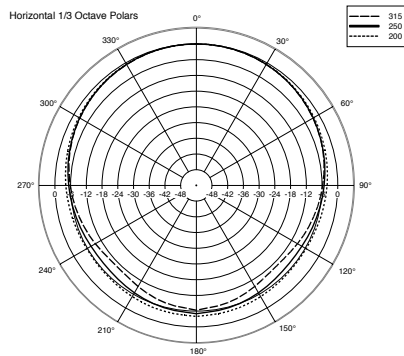

VERTICAL 1/3 POLAR PLOT

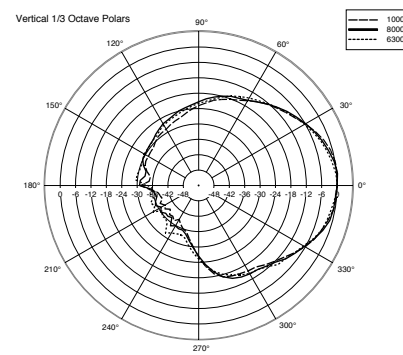
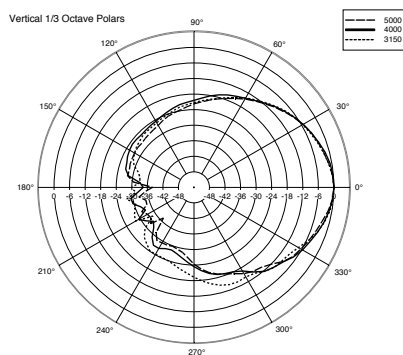
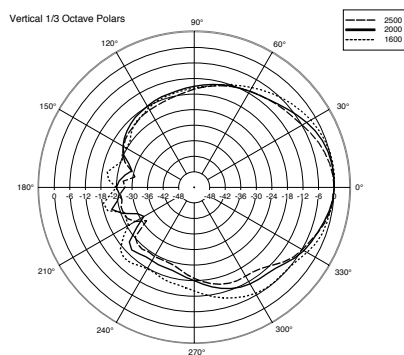
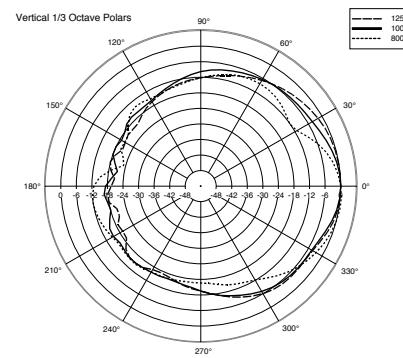
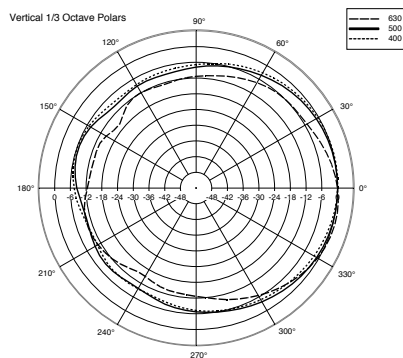
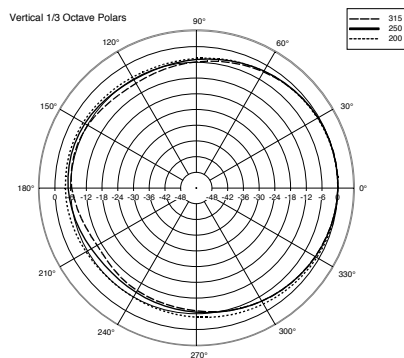

D-LINE HD32-A

PART NUMBERS

13040018 - 230VOLT

13040019 - 115 VOLT

DIMENSIONS (All data are in mm)

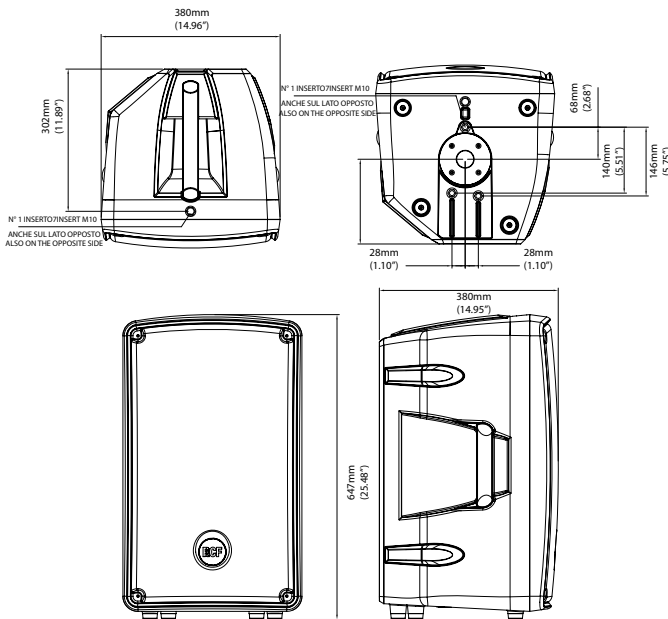

ACOUSTICAL SPECIFICATIONS

Frequency response:	45 Hz- 20 KHz
Max SPL:	131 dB
Horizontal coverage angle:	90°
Vertical coverage angle:	60°
Compression driver:	2.0", 3" voice coil
Midrange:	-
Woofer:	12", 2.5" voice coil

INPUT SECTION

Input signal (Impedance):	bal/unbal
Input/Output connector:	Jack-XLR male
Input sensitivity:	-2 dBu / + 4 dBu

PROCESSOR SECTION

Crossover frequencies:	800 Hz
Protections:	Themel, RMS
Sensitivity control:	yes
Limiters:	soft limiter
High pass:	-
Controls:	Volume, EQ shape, Mic/line

ACCESSORIES

AC S260	Steel speaker floor stand with folding base and telescopic rod, tube diameter 35mm. Load capacity up to 60kg, Weight 7.8 Kg, H MIN/MAX 170cm/240cm. Length once folded 123cm
AC S140	Aluminium speaker floor stand with folding base and telescopic rod, tube diameter 35mm. Load capacity up to 40kg, Weight 2.7 Kg, H MIN/MAX 140cm/214cm. Length once folded 107cm
AC PRO-FS	Steel speaker floor stand with folding base and telescopic rod, tube diameter 35mm. Load capacity up to 50kg, Weight 4.5 Kg, H MIN/MAX 137cm/210cm. Length once folded 102cm
AC PRO-LF	Steel professional adapter sleeve for speaker floor stand, tube diameter 35 mm. Load capacity up to 50Kg, Weight 0.7 Kg, H 27.5 cm
AC PRO-PM	Steel pole mount accessory for a satellite speaker on a subwoofer, tube diameter 35 mm. Load capacity up to 35Kg, Weight 2.4 Kg, H MIN/MAX 95cm/137cm
AC EB4X	Kit including No. 4 shouldered 10mm eye bolts
AC PMA	Speaker pole mount
AC HD-FD 12 H-BR	Horizontal bracket for HD12-A and FD 12-A speakers
Cover HD-FD 12	Cover for HD12-A and FD 12-A speakers

AMPLIFIER

Power supply:	switching 700 Watt
High frequencies:	D / 200 Watt
Mid frequencies:	-
Low frequencies:	D / 500 Watt
Cooling:	convection
Connection:	Powercon in-out

PHYSICAL

Height:	647 mm (25.47")
Width:	380 mm (14.96")
Depth:	380 mm (14.96")
Weight:	34 kg (74.95 lbs)
Cabinet:	Composite PP
Hardware:	1 x M10 top, 1 x M10 bottom, 3 x M6 bottom
Handles:	1 top, 2 side
Pole mount cap	yes
Colour:	Black